

**Characteristics / Ordering Code**

Check valves from the Parker series CM are in sandwich design for easy configuration of stack systems. Depending on the function required, one or two check valves are arranged in ports P, T, A, and B. Number and flow direction can be selected from the ordering code.

**Features**

- The valve bodies of the Parker valve series CM are made of steel.
- Eight options for the arrangement of the check valve in the body offer a multitude of uses for hydraulic circuits.
- CM2 - NG06 (CETOP 03)
- CM3 - NG10 (CETOP 05)

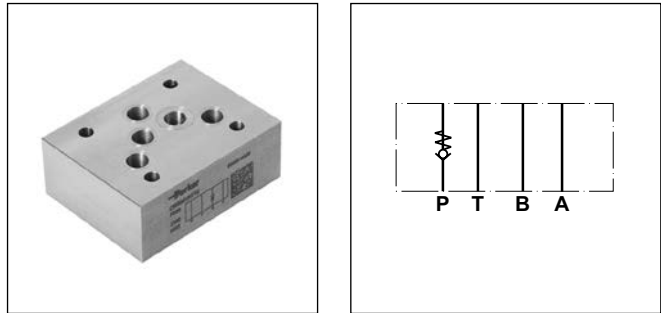

CM3

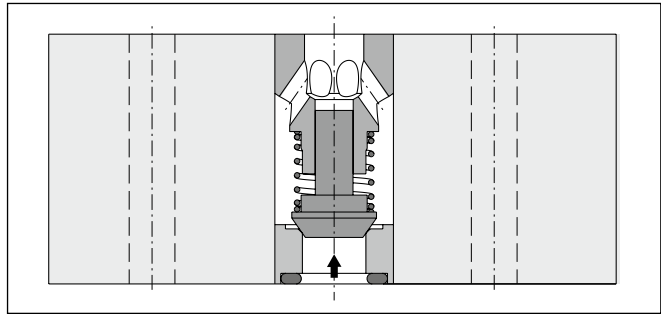

**Ordering code**

7

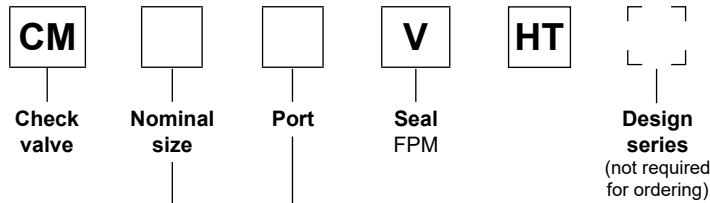

Code	Nominal size
2	Intermediate plate DIN NG06
3	Intermediate plate DIN NG10

Code	Free flow polarity	Check valve in channel
AA	From directional valve to manifold	A
BB	From directional valve to manifold	B
DD	From directional valve to manifold	A and B
PP	From manifold to directional valve	P
PT	From manifold to directional valve	P and T
TT	From directional valve to manifold	T
AAF	From manifold to directional valve	A
BBF	From manifold to directional valve	B

**Technical data**

General		CM2	CM3
Series		<b>CM2</b>	<b>CM3</b>
Size		<b>NG06</b>	<b>NG10</b>
Mounting interface		DIN 24340 A6 ISO 4401 NFFPA D03	DIN 24340 A10 ISO 4401 NFFPA D05
Mounting position		unrestricted	
Ambient temperature	[°C]	-20...+70	
MTTF <sub>D</sub> value	[years]	150	
Weight	[kg]	0.7	2.0
Hydraulic			
Max. operating pressure	[bar]	350	350
Max. flow	[l/min]	60	120
Opening pressure	[bar]	0.5	0.5
Fluid		Hydraulic oil according to DIN 51524	
Fluid temperature	[°C]	-20...+70	
Viscosity ,	permitted	20...400	
	recommended	30...80	
Filtration		ISO 4406; 18/16/13	

**Schematics**

The valve side is shown at the top of the symbols, the manifold side with channel designation is shown at the bottom.

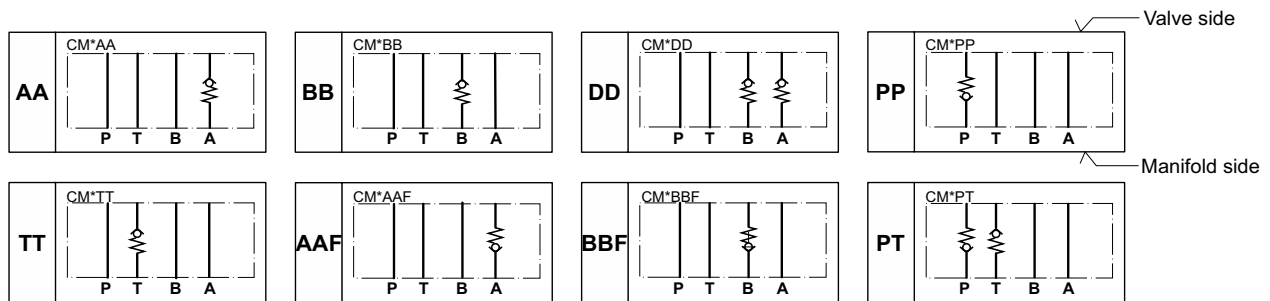

**Δp/Q performance curves**

**CM2**

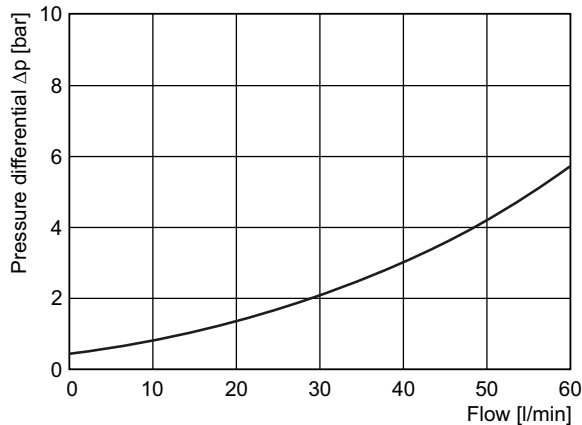

**CM3**

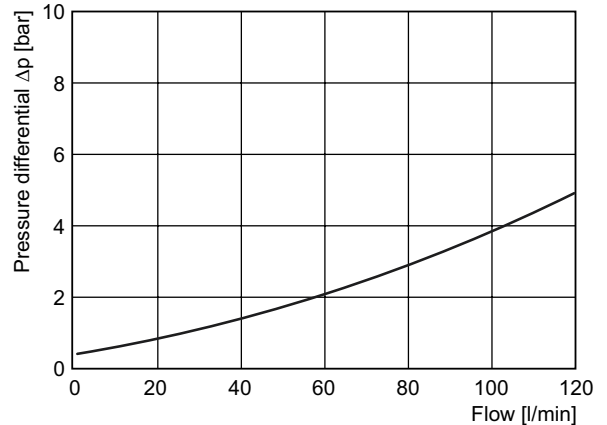

Measured with oil viscosity 33.0 mm<sup>2</sup>/s (cSt)

**CM2**

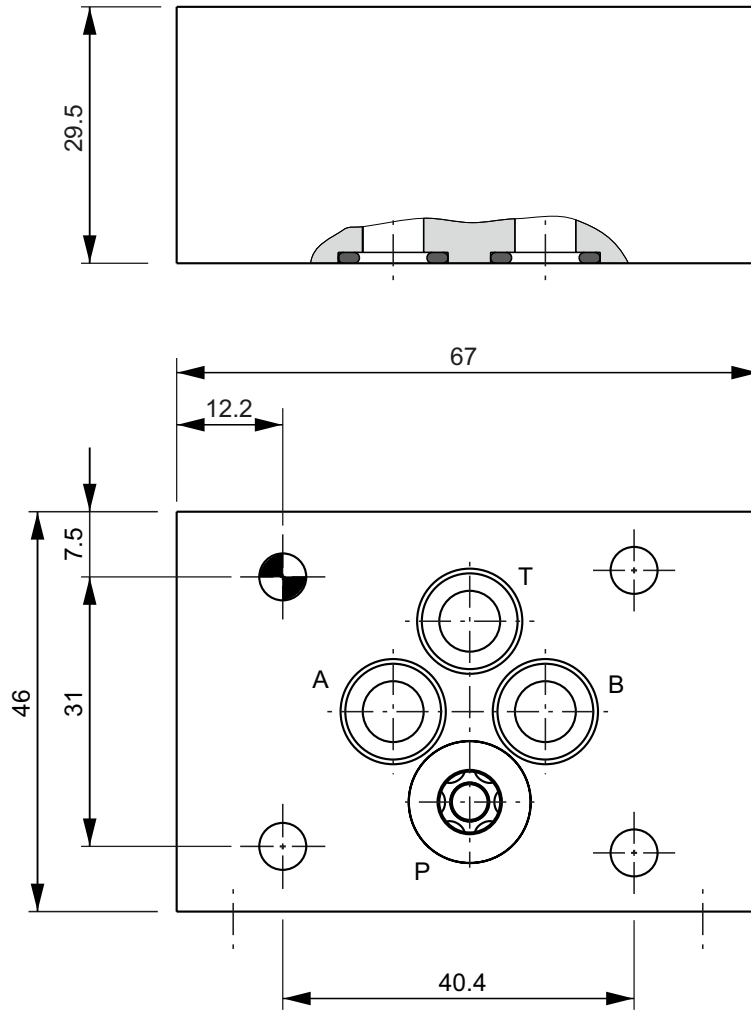

7

Seal kit CM2	
Seal	Order code
V	SK-CM2-V

**CM3**

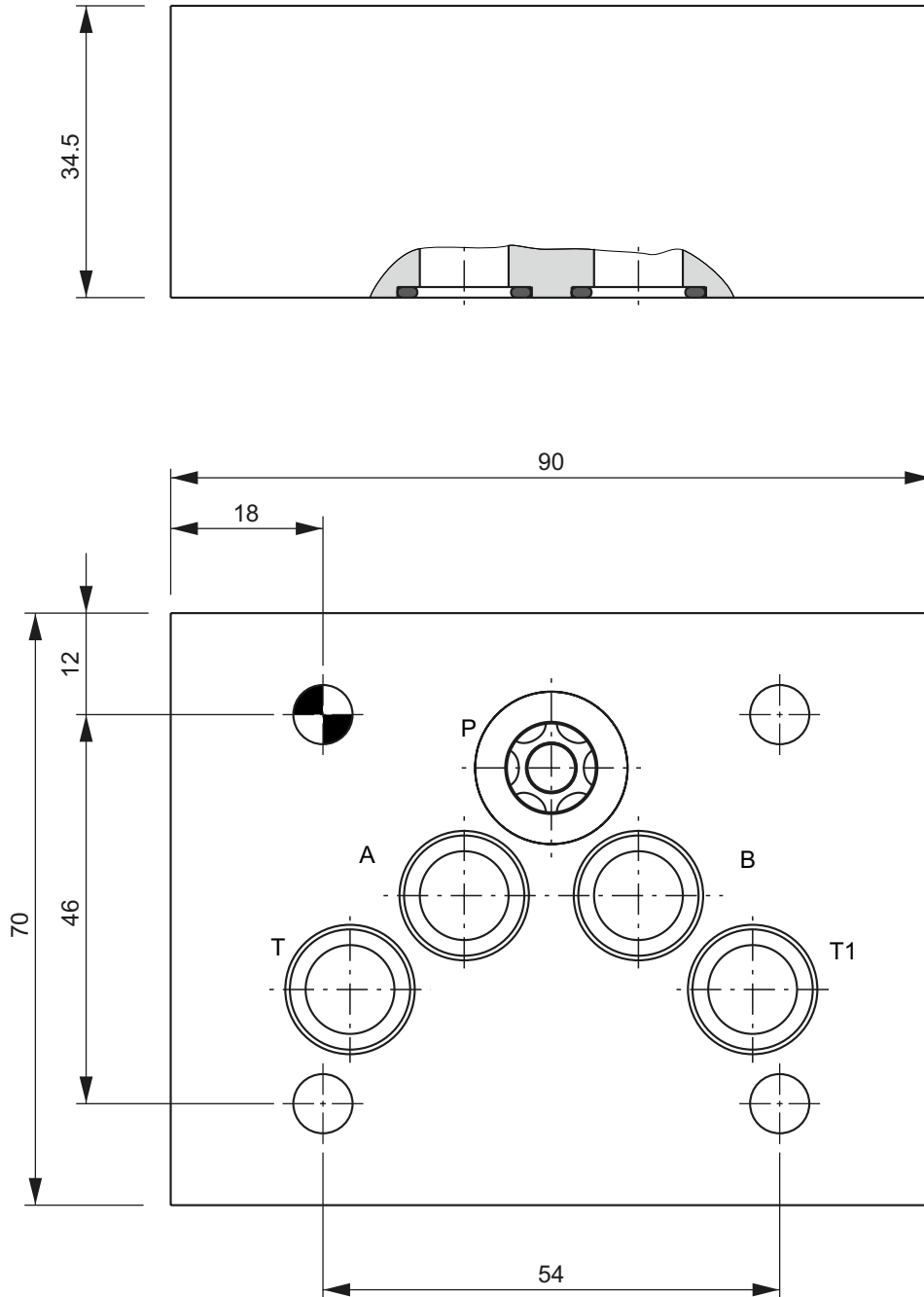

7

Seal kit CM3	
Seal	Order code
V	SK-CM3-V